

# Hydraulic Vapor Valve

2" Tee Valve

- Hydraulically Operated
- Hydraulic System Isolated from Product
- Quick Removable Clamp Ring Tophead for Easy Cleaning
- Complies with TTMA RP 102
- 316 Stainless Steel with Teflon® Seals

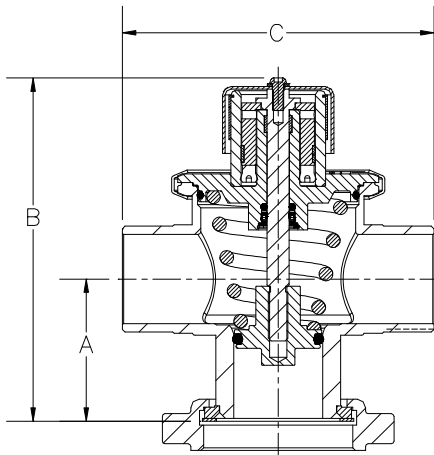
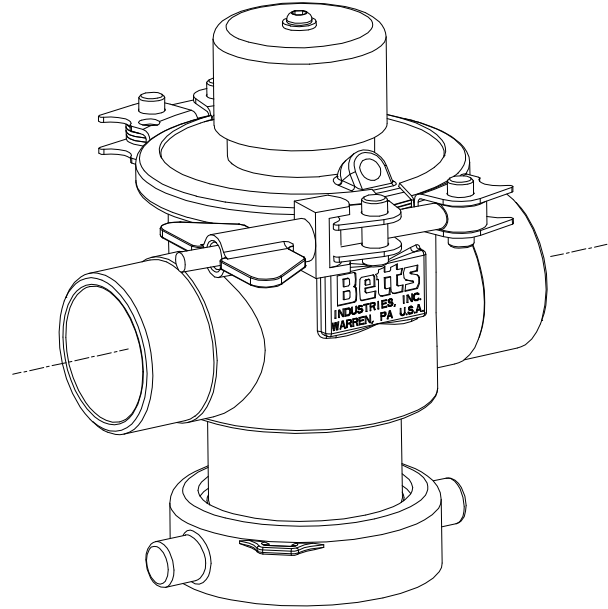

The Betts Stainless Steel 2" Tee Style Vapor Recovery Valve complies with recommendations of TTMA RP 102. The unique clamp ring style tophead allows for quick removal of hydraulic actuator and internal components so valve body can be cleaned without removing body from tank. By using flexible hydraulic line to connect to actuator, hydraulic line does not need to be disconnected to remove tophead. Tee style design allows for plumbing vapor connection at top of tank and at street level for maximum flexibility. Outward opening design provides full flow area for 2" pipe.

Design of hydraulic cylinder isolates hydraulic oil from lading. Visual indicator confirms when valve is open. Body constructed of 316 stainless steel with Teflon® seals exposed to lading.

A	B		C	MOUNT	OUTLETS	THRU AREA	*ACUTATION PRESSURE	TEMP. RANGE	**MAWP	WT.	ASSEMBLY NO.
	Open	Closed									
3.19"	9.06"	7.71"	7.0"	3" NPT	2" NPT	3.14in <sup>2</sup>	250 psi	-40°F to 250°F	50 psi	12.8 lb.	CH46819SSTS

\* 3000 psi maximum hydraulic pressure. Use Betts pump with 3000 psi bypass setting.

\*\* Remove from cargo tank during pressure test per 49CFR178.345-13(b) and 49CFR180.407(g)(1)(vii) if cargo tank test pressure exceeds 50 psi.

PARTS LIST

# Hydraulic Vapor Valve

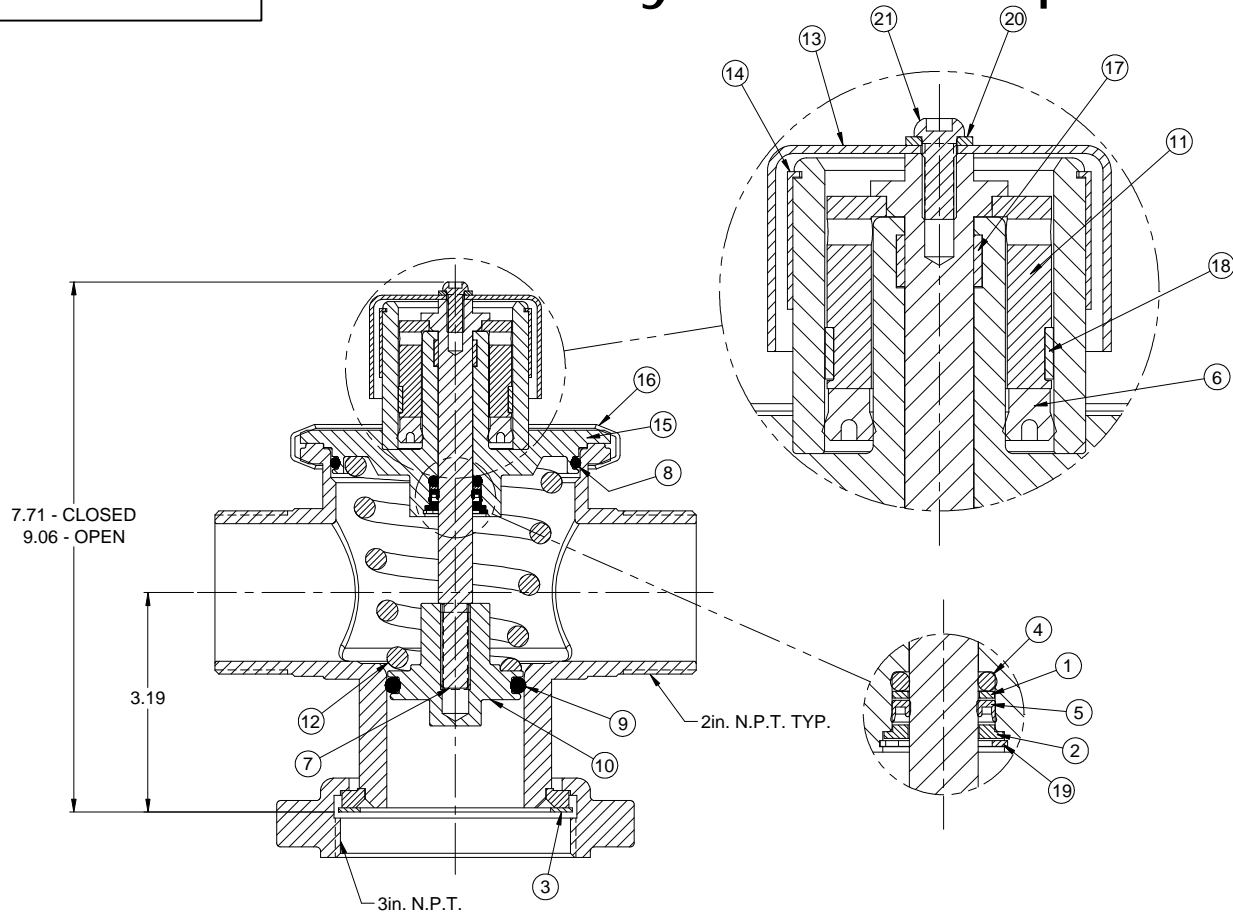

NO.	REQ'D.	PART NO.	MATERIAL	DESCRIPTION
1	1	19393SS	316 SS	SEAL RETAINER
2	1	19395SS	316 SS	SEAL RETAINER
3	1	19397TF	TEFLON	MOUNTING SEAL
4	1	19509TS	TEF/SIL	O-RING – STEM
5	1	19510SSTF	316 SS/TEF	U-CUP SEAL – STEM
6	1	19838PM	POLYESTER	HYDRAULIC U-CUP SEAL
7	1	19840SS	316 SS	STEM
8	1	19843TS	TEF/SIL	O-RING – TOPHEAD
9	1	19844TS	TEF/SIL	O-RING – SEAT
10	1	19873SS	316 SS	O-RING HOLDER
11	1	19882SS	316 SS	HYDRAULIC PISTON
12	1	19884SS	316 SS	MAIN SPRING
13	1	19893SL	304 SS	RAIN CAP
14	1	19894PE	POLYETHYLENE	INDICATOR
15	1	27921SS	316 SS	HYDRAULIC TOP HEAD & CYLINDER ASSEMBLY
16	1	28114SL	304 SS	CLAMP RING ASSEMBLY
17	1	8N9426	POLYESTER/PTFE	STEM BUSHING
18	1	8N9427	POLYESTER/PTFE	PISTON BUSHING
19	1	9Q4943	15-7 Mo SS	INT. RET. RING (7/8)
20	1	9Q5844	304 SS	LOCK WASHER 1/4 in. SS
21	1	9Q5952	18-8 SS	1/4 -28UNF x .50 BUTTON HEAD CAP SCREW

WARNING Use only BETTS INDUSTRIES INC. replacement parts. Use of substitute parts can impair the proper function of this product.