

4" High Flow Emergency Valve, Mechanical

FEATURES AND BENEFITS

Specifically designed for ease of maintenance, high flow and durability the simplicity of the design of this valve make it ideally suited to oil companies and transporters of petroleum products who require a tough, reliable, high flow emergency valve.

- **High quality** die cast body and component materials to international standards are used for durability and performance.
- **Lightweight** aluminium construction for increased payloads.
- **Packed gland** shaft for easy servicing.
- **Plug fitted** ready for dryline application.
- **All running surfaces** are bushed for smoother operation and longer service.
- **High lift** poppet for maximum flow.
- **Shear groove** meets TTMA and NTTC DOT 406 to limit product spillage in the event of an accident.
- **Closure** by self centring plunger and durable compression spring.
- **Removable bonnet** assembly enables seal change without removing valve from the tank
- **Stainless steel** cam with bearing boot on plunger stem for smooth operation and extended life.
- **Victaulic and TTMA** flanged variants available.
- **Dryline ready** for proposed future regulations.
- **Air cylinder kit** available.



EMERGENCY VALVE

VARIANTS

PART NO.	DESCRIPTION	WEIGHT
F7010.041	Flanged Elbow Viton® Seal	9.35 lbs
F7010.042	Flanged Elbow PTFE Seal	9.35 lbs
F7010.043	Flanged Elbow Buna Seal	9.35 lbs
F7011.041	Victaulic Elbow Viton® Seal	9.07 lbs
F7011.042	Victaulic Elbow PTFE Seal	9.07 lbs
F7011.043	Victaulic Elbow Buna Seal	9.07 lbs

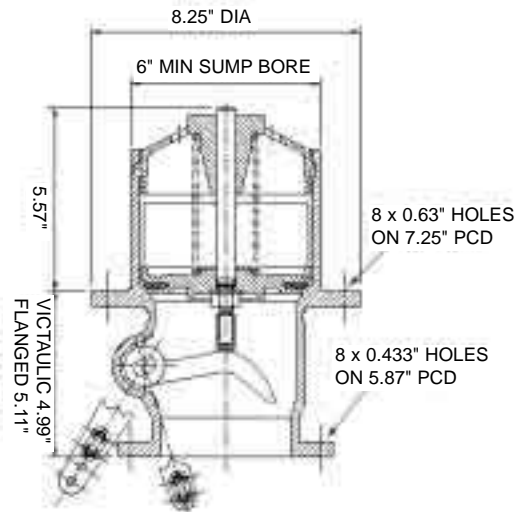

F7010 & F7011

4" High Flow Emergency Valve, Mechanical

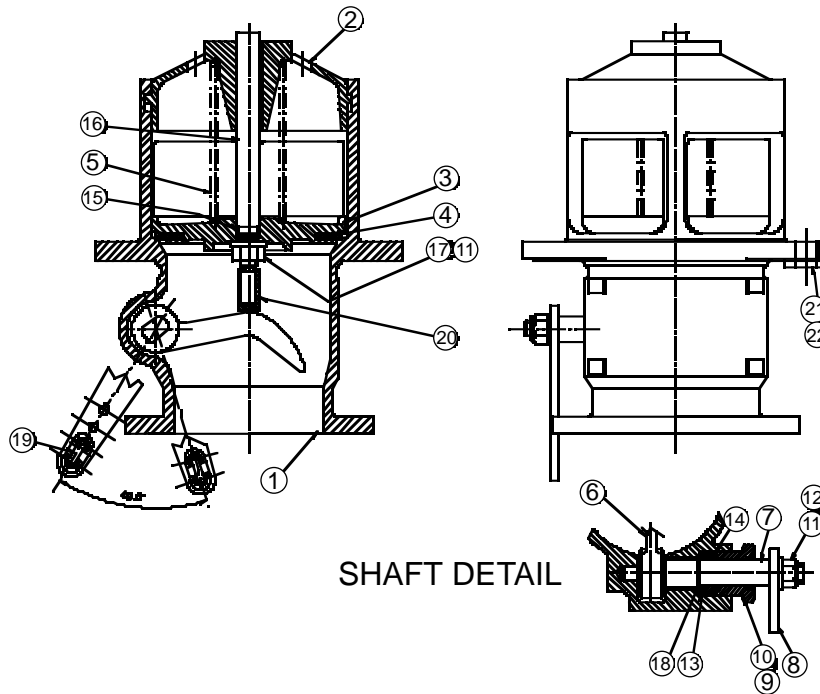

SPECIFICATIONS

Ref	Description	F7010041	F7011041	Qty
1	Body	670536	670536	1
2	Cap	619511	619511	1
3	Poppet	619513	619513	1
4	Seal Disc	615992	615992	1
5	Spring	577264	577264	1
6	Cam	619516	619516	1
7	Cam Spindle	670557	670557	1
8	Lever	619533	619533	1
9	Gland Nut	670560	670560	1
10	O-Ring Buna	670569	670569	1
11	M12 Nyloc Nut	618841	618841	2
12	Plain Washer	599007	599007	1
13	Packing Support Washer	670561	670561	1
14	Gland Packing	407804	407804	2
15	O-Ring	603653	603653	1
16	Poppet Stem	619514	619514	1
17	Shakeproof Washer	619532	619532	1
18	Retaining Ring	670570	670570	1
19	U - Bolt	452710	452710	1
20	Poppet Stem Boot	619515	619515	1
21	Sealing Ring Nylon	670545	670545	1
22	Blanking Plug	670544	670544	1



printed on recycled paper

As part of a continuous commitment to product development the Company reserve the right to alter the specification of its products without prior notice.